

PM-icx the Intelligent answer



PM-icx Power Monitors

***GAS SUPPLY CONTROL STATION
with
Fan Power Ventilation Inter-lock
For Models: PM-1icx / PM-2icx***

***INSTALLATION and COMMISSIONING
INSTRUCTIONS***

PM-icx the Intelligent answer

Product Overview

The **PM-icx** Fan power monitor unit is part of a range of products and ancillary equipment designed to meet the ever changing requirements of the catering industry and associated regulations.

The system comes in a number of models for you to select which are based on our patented system.

The controller has been designed to make for easy system commissioning.

Contents

- 1.0 General Info
 - 1.01 Opening the unit
 - 1.02 Fixing details
 - 1.03 Cable entry
 - 1.04 Electrical connections
 - 1.05 Component locations
- 2.0 Set-up and commissioning
 - 2.01 Initial Set-up
 - 2.02 Functional Set-up
- 3.0 Fault finding
- 4.0 Wiring and connection details
- 5.0 Technical specification

1.01 Opening the unit

The **PM-icx** unit is made up of three (3) main component parts, one (1) PCB (printed circuit board), base enclosure and facia.

The enclosure and facia are held together via four screws, the base enclosure houses the main PCB (printed circuit board) and the facia is attached to it via a multi-core ribbon cable.

To open the enclosure, first remove the four screws; lift off the facia and unclip the ribbon cable from the main PCB.

Place the screws and facia in a safe place until the base enclosure has been fixed, wired and is ready for reassembly and set-up.

1.02 Fixing details

The **PM-icx** unit has four (4) mounting holes which can be used (as shown)

Note: Ensure that the enclosure is mounted on a clean and level surface away from the direct cooking area or surfaces.

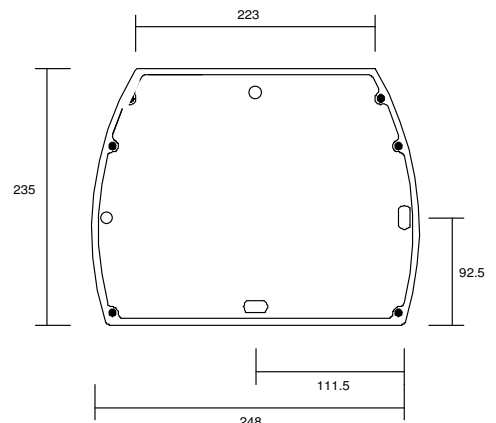

1.03 Cable entry

The **PM-icx** unit has space above, below and from behind the unit to allow for cable entry holes to be drilled. Care should be taken to prevent the PCB from damage.

1.04 Electrical connections

The **PM-icx** unit has a 5Amp MCB on/off rocker switch for protection of the unit. There are two sets of terminals mounted along the edges of the main PCB circuit board.

Terminals 1 to 18 are the smaller terminals (1.5 mm² cable) and are used for the inter-locking devices such as “fire alarm” and “remote knock-off units”.

Terminals 19 to 41 are the larger terminals (4 mm² cable) and are for the power connections for the fans, gas valve and power supply to the unit.

The terminals are of the rising clamp type with protection.

All cabling should be kept to the top or bottom of the unit within the designated area. No cables should be placed or laid across the PCBs as they may cause damage.

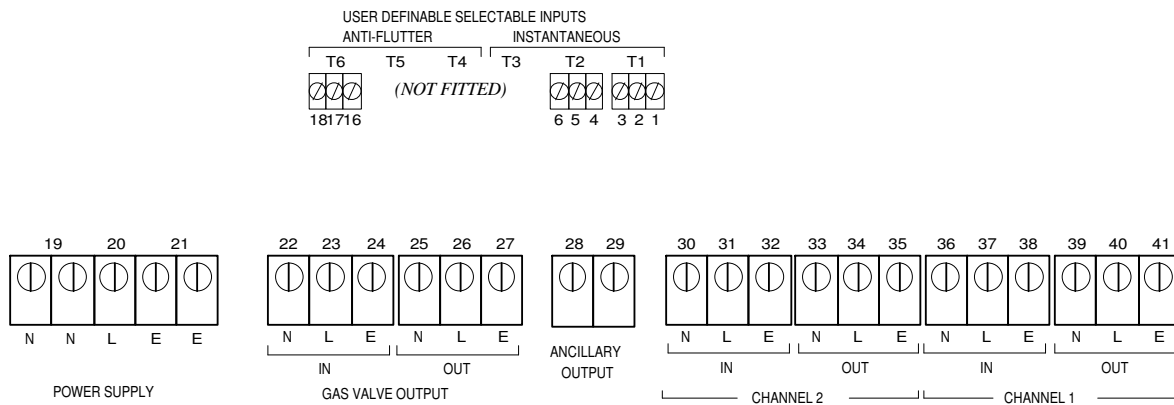

1.05 Component Locations

The **PM-icx** unit has a number of components which need to be adjusted to set the system correctly. These are located at the top of the main PCB, under the left hand terminals and bottom right as detailed.

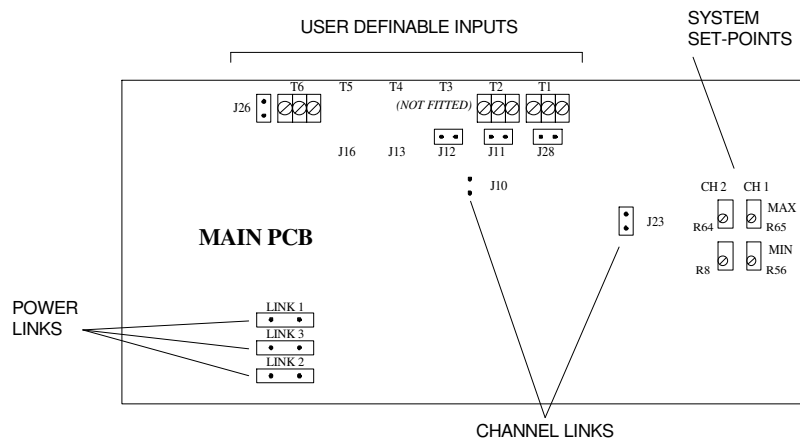

PM-icx the Intelligent answer

Follow these instructions to correctly set-up your unit.

2.0 Set-up and Commissioning

The set-up and commissioning of your **PM-icx** unit is in two parts, **Initial** and **Functional**.

2.01 Initial Set-up

Once all of the wiring has been completed and tested and the system is ready to be set-up and commissioned, the following sequence **MUST** be followed to ensure the **PM-icx** unit and system operate correctly.

- a) **Input Jumpers**, Ensure that the correct input jumpers have been removed as detailed in sections: 4.0 & 5.0. (located as detailed in 1.05)
- b) **Power Links**, Ensure that these links have been selected correctly for your installation as detailed in sections: 4.0 & 5.0. (located as detailed in 1.05)
- c) **Channel Link**, If you are using the PM-2ic as a single channel unit, remove Link **J23** and place it in position **J10** located as detailed in 1.05. **Note:** When the system has been set to a single channel unit – channel 2 is ignored for fan proving purposes
- d) Ensure that fire alarm and knock-off switches (if fitted) are all in the operational position.
- e) Refit the **PM-icx** unit facia plate by plugging in the ribbon cable and fixing the four screws of the facia, with the top cover plate removed so the system can be commissioned.
- f) Ensure that you have set-up your fans, balanced the air system and you have set the min speed on the speed controllers (*if fitted*) to the minimum design air flow rate for the area.

2.02 Functional Set-up

Once the above has been carried out, the system is now ready to be powered up. The upper and lower current limits need to be established to ensure correct operation of the gas valve interlock.

2.02.1 Working on one channel at a time, (CH 1 and then CH 2):

Before you start, turn the MAX pot (R65 / R64) approximately 30 times **CLOCKWISE**.

To set the **MINIMUM** current:

1. Set the respective fan to its **MIN** speed and then set the MIN pot (R56 / R8) to its set point by adjusting the pot **ANTI-CLOCKWISE** until the green LED above the pot is on. (*If green LED is on to start with, adjust **CLOCKWISE** until it goes off and back **ANTI-CLOCKWISE** to bring it on again*).
2. Adjust the same fan **slowly** from its **MIN** speed to its **MAX** speed; if the green LED goes off at any point, adjust the MIN pot **ANTI-CLOCKWISE** until it comes back on.
3. When the fan is at its **MAX** speed, turn the MIN pot one further full turn **ANTI-CLOCKWISE** to allow for any fluctuations. This pot is now set, and does not need to be adjusted again.

To set the **MAXIMUM** current:

1. Set the MAX pot (R56 / R8) to its set point by adjusting the pot **ANTI-CLOCKWISE** until the green LED above the pot is off, and then turning the pot **CLOCKWISE** until the LED comes back on.
2. Adjust the same fan **slowly** from its **MAX** speed to its **MIN** speed; if the green LED goes off at any point, adjust the MAX pot **CLOCKWISE** until it comes back on.
3. When the fan is at its **MIN** speed, turn the MAX pot one further full turn **CLOCKWISE** to allow for any fluctuations. This channel is now set correctly, and you can proceed to the second channel (if required).

2.02.2 When both channels have been set, press the green **SYSTEM SET** pad once, the gas valve LED will go to **GREEN** and the gas valve output and ancillary output will be activated.

PM-icx the Intelligent answer

2.02.3 With the system running and the gas valve output on, the following tests should be carried out.

- 1) Press the Emergency Gas Shut Off on the front of the panel; the gas valve output will go off and the gas valve output LED will go out and the alarm will sound.
- 2) Press the blue ALARM MUTE pad and twist Emergency Gas Shut Off to release it and press the green SYSTEM SET pad to restart.
- 3) Repeat this for any remote knock-off button fitted and the fire alarm.
- 4) Switch off each fan in turn and watch the gas valve output go off.
- 5) Switch the fans back on, and press the green SYSTEM SET pad to restart. Set each fan to a few different speeds and leave for a short time to ensure the gas valve output stays on.
- 6) The set-up is now complete and the system is ready for normal operation.

2.02.5 Adjustment POTs

The two adjustment POTs per channel are multi-turn units (approx: 30 turns). These enable fine setting of the two switching points (min & max).

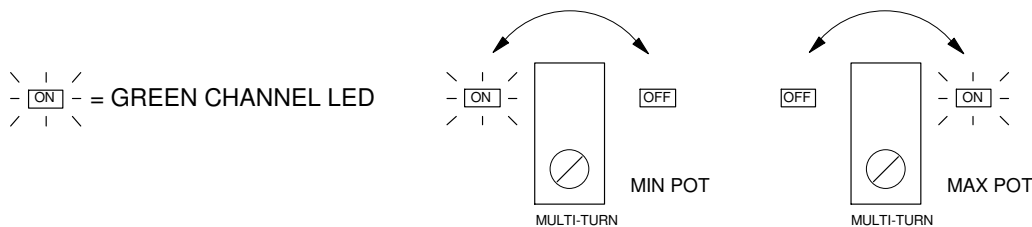

3.0 Fault finding

In the event that your PM-icx unit has not operated, the following has been designed to help you identify your problem and offer a course of action for you to take.

Fault finding Only to be carried out by a qualified engineer

Fault		Possible cause	Action
No Power On LED	a.	No power to the unit	Check power supply to unit, mains cables and terminals
	b.	Primary transformer fuse "blown"	Remove cover and check if "blown". If yes, check for any signs of a wiring fault and rectify before replacing with a new fuse.
	c.	None of the above	Call for further assistance
Gas valve output lamp is not lit and gas valve is closed	a.	Fans are not running	Check that the fans are running correctly
	b.	Fans are running but unit not set correctly	Check that the respective channel lamps are on. Action as detailed in set-up instructions
	c.	User definable input operated	Check if remote knock-off and fire alarm inputs and any other remote circuits have been activated
	d.	Emergency Gas Shut off push button on the front of the unit has been pressed	Twist and reset
Gas valve output lamp is on and gas valve is closed	a.	No power to gas valve	Check in / out terminals to see if 240Vac is present and check cables to gas valve.
	b.	Gas valve not operational	Check if 240Vac is present at gas valve terminals. If yes replace gas valve.
Gas valve open but no gas at appliance	a.	Gas supply has been isolated or is blocked	Check gas supply
	b.	No gas pressure	Check gas supply
Channel lamp not on	a.	Fans are not running	Check that the fans are running correctly
	b.	Fans are running but unit not set correctly	Check that the respective channel lamps are on. Action as detailed in set-up instructions

4.0 Wiring and connection details

The following information should be read in conjunction with the respective PM wiring diagram for your model.

User definable inputs (Screened cable recommended)

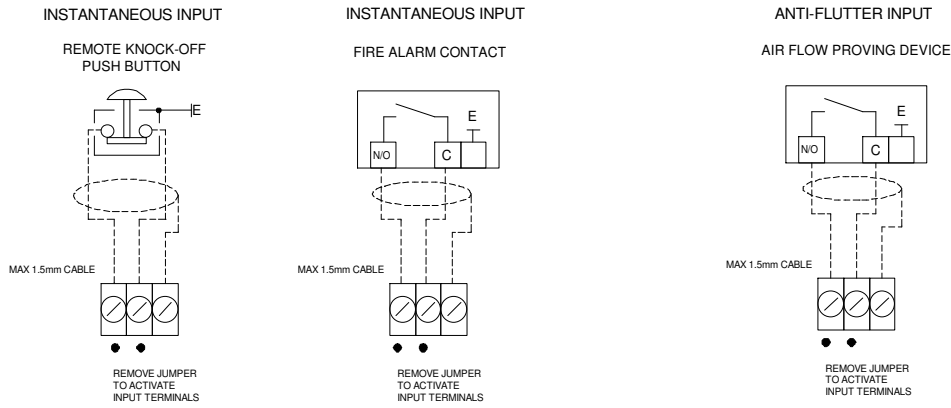

Gas Valve Output

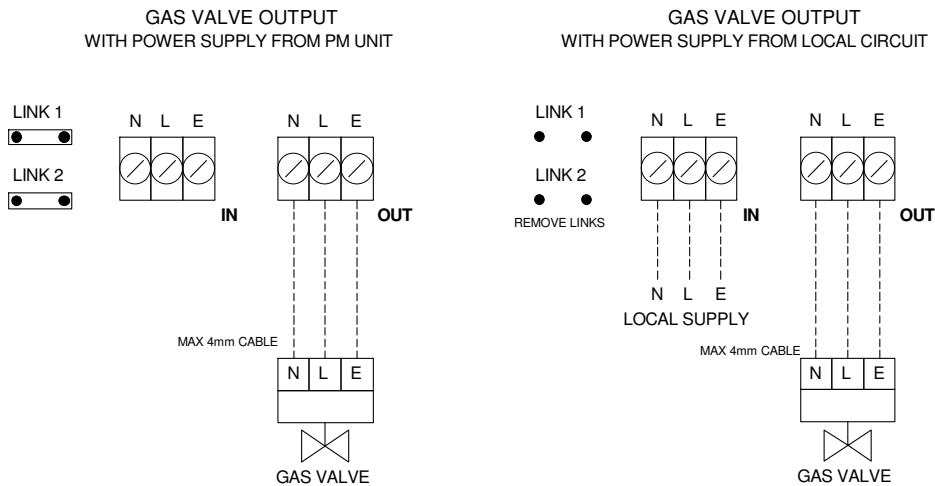

Ancillary Output (Electric Fryer etc)

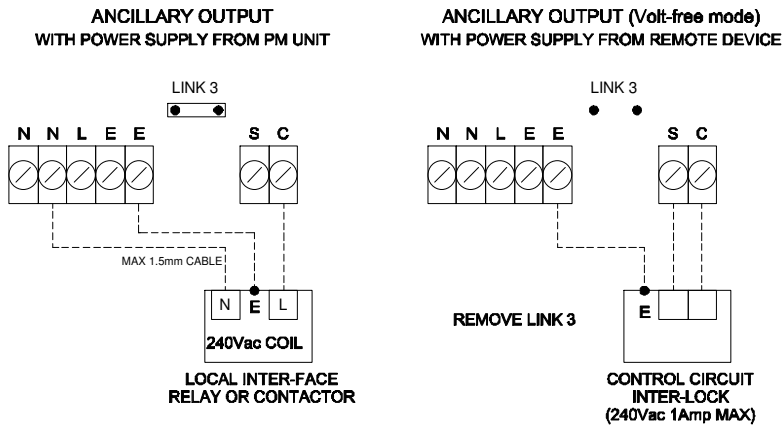

PM-icx the Intelligent answer

5.0 Technical Specification

The following information should be read in conjunction with the wiring diagram for the model being fitted and commissioned. It is correct at the time of going to print, but we reserve the right to change at any time the materials and information hereto detailed.

Inputs:

- fan Power 240Vac 50Hz (0 – 10 Amps max each channel) *Optional 20Amp*
- optional Fire alarm and / or Carbon Monoxide sensor
- optional Air Flow differential pressure switch or proving product
- optional Remote emergency stop

Outputs:

- fan Power 240Vac 50Hz (0 – 10 Amps max each channel) *Optional 20Amp*
- gas Valve output selectable 240Vac or Volt-free contact (6 Amp 240Vac 50Hz)
- ancillary output selectable 240Vac or Volt-free contact (4 Amp 240Vac 50Hz)

PCB adjustments and jumper links (Main PCB – issue 9):

MIN	Current level switch point	0 to 10 Amps (each channel)
MAX	Current level switch point	0 to 10 Amps (each channel) 30 sec delay *
J28	Remote emergency stop	Yes/No
J11	Fire alarm	Yes/No
J26	Air flow DPS (<i>if required</i>)	Yes/No (Anti-flutter)
J10/23	Channel select	Yes/No
LED	Green indicator	Current switch point (each channel)
LED	Red indicator	Gas valve output activated

Front of unit indication and pads (Facia PCB – issue 2):

LEDs

Power on			
Gas Valve Output	<i>Off</i>	=	<i>Closed</i>
	<i>Green</i>	=	<i>Open</i>
Fan 1 & 2	<i>Off</i>	=	<i>Fault</i>
	<i>Green</i>	=	<i>Running</i>

PADS

System Set	<i>Green</i>	=	<i>Start system when fans are running</i>
Alarm Mute	<i>Blue</i>	=	<i>Mute audible alarm</i>

Power supply:	240Vac 50Hz	5Amp	MCB rocker switch (illuminated Red)
Transformer:		F3	1Amp Primary Transformer Fuse
Consumption:	Approx 5VA		
Housing:	IP 54		
Dimensions:	250 x 235 x 60mm (approx)		
Ambient range:	-10 to +40 Deg.C		
Country of Origin:	UK		

Note: The MAX current level settings have a 30 sec over current delay before switching off the gas valve and ancillary outputs.

PM-icX the Intelligent answer

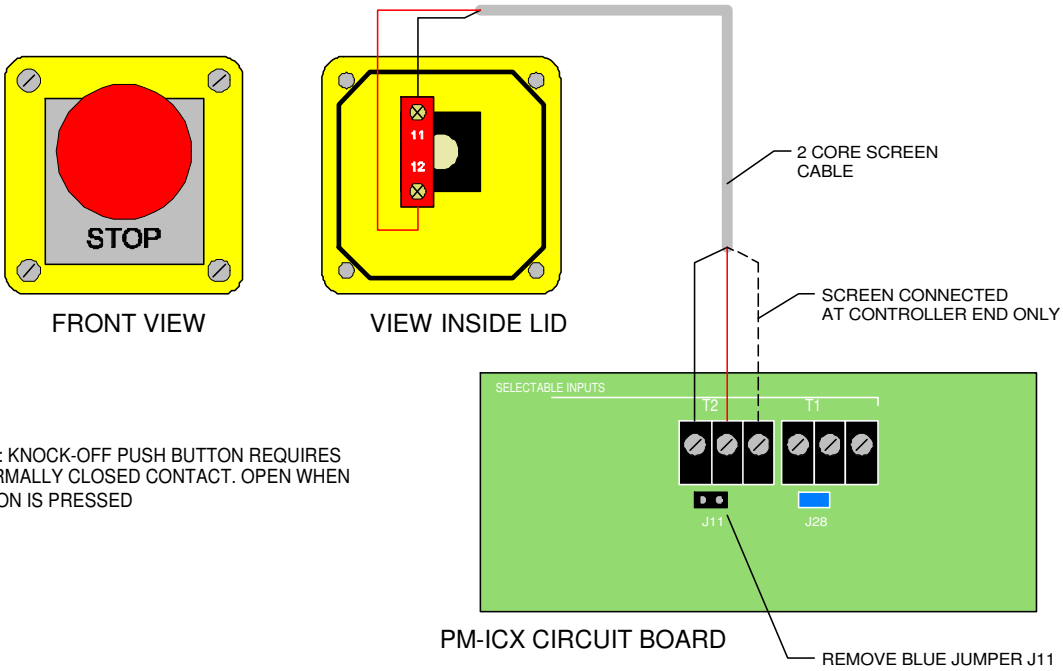

NOTE: KNOCK-OFF PUSH BUTTON REQUIRES A NORMALLY CLOSED CONTACT. OPEN WHEN BUTTON IS PRESSED

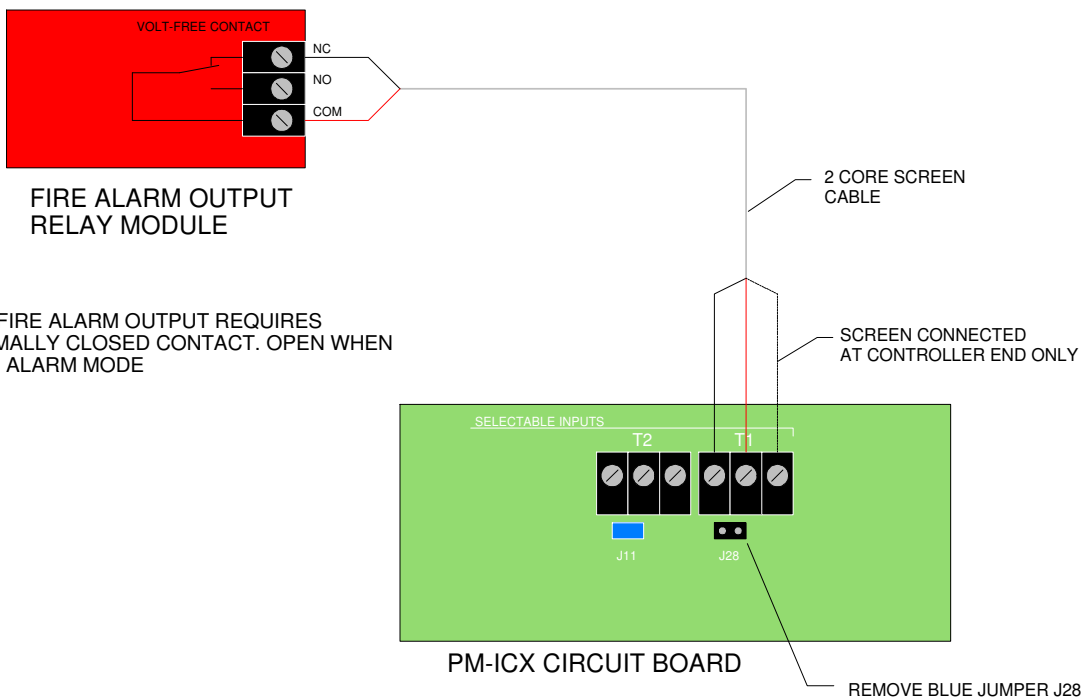

NOTE: FIRE ALARM OUTPUT REQUIRES A NORMALLY CLOSED CONTACT. OPEN WHEN IN FIRE ALARM MODE

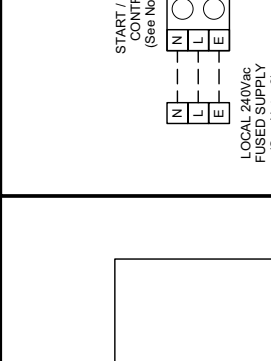
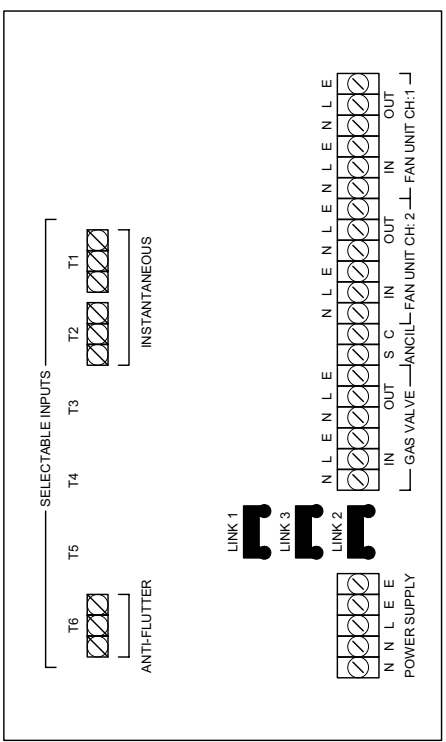
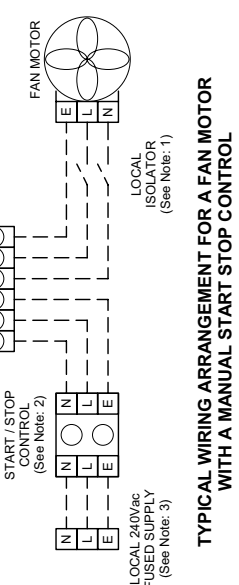
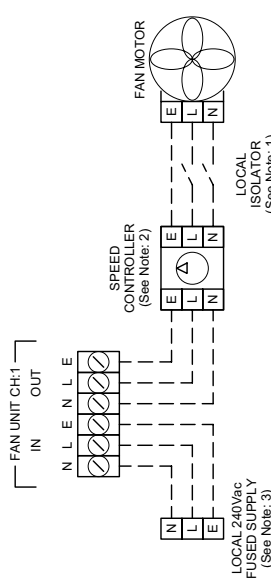
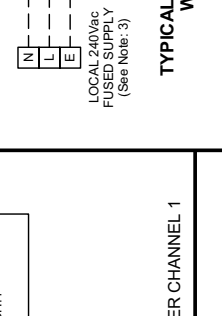
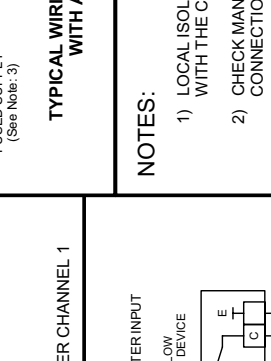
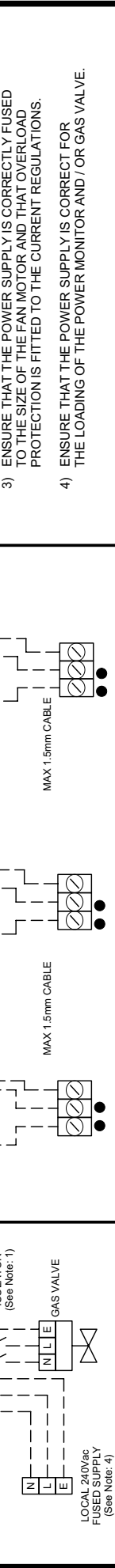
0	1	2	3	4	5	6	7	8	9		
 <p>PM UNIT POWER SUPPLY</p>		 <p>GAS VALVE OUTPUT WITH POWER SUPPLY FROM PM UNIT</p>		 <p>GAS VALVE OUTPUT WITH POWER SUPPLY FROM LOCAL SUPPLY (with LINKS 1 & 2 removed)</p>		 <p>CIRCUIT BOARD LAYOUT</p>		 <p>TYPICAL WIRING ARRANGEMENT FOR A FAN MOTOR WITH A MANUAL START STOP CONTROL</p>		 <p>TYPICAL WIRING ARRANGEMENT FOR A FAN MOTOR WITH A MANUAL SPEED CONTROLLER</p>	
<p>REPEAT POWER WIRING FOR CHANNEL 2 AS PER CHANNEL 1</p> <p>SELECTABLE INPUTS</p> 											
<p>NOTES:</p> <ol style="list-style-type: none"> 1) LOCAL ISOLATION MUST BE PROVIDED IN ACCORDANCE WITH THE CURRENT EDITION OF THE IEE REGULATIONS. 2) CHECK MANUFACTURER'S WIRING DETAILS FOR CORRECT CONNECTIONS AND SET-UP REQUIREMENTS. 3) ENSURE THAT THE POWER SUPPLY IS CORRECTLY FUSED TO THE SIZE OF THE FAN MOTOR AND THAT OVERLOAD PROTECTION IS FITTED TO THE CURRENT REGULATIONS. 4) ENSURE THAT THE POWER SUPPLY IS CORRECT FOR THE LOADING OF THE POWER MONITOR AND / OR GAS VALVE. <p style="text-align: center;">IF IN DOUBT, ASK</p>											
<p>TRENT PRODUCTS</p> <p>Tel: 01782 - 844688 Fax: 01782 - 844772</p>		<p>DATE:</p> <p>01/11/06</p>		<p>DRAWING No:</p> <p>PM-1cx-WD01</p>		<p>DRAWN BY</p> <p>MAE</p>					

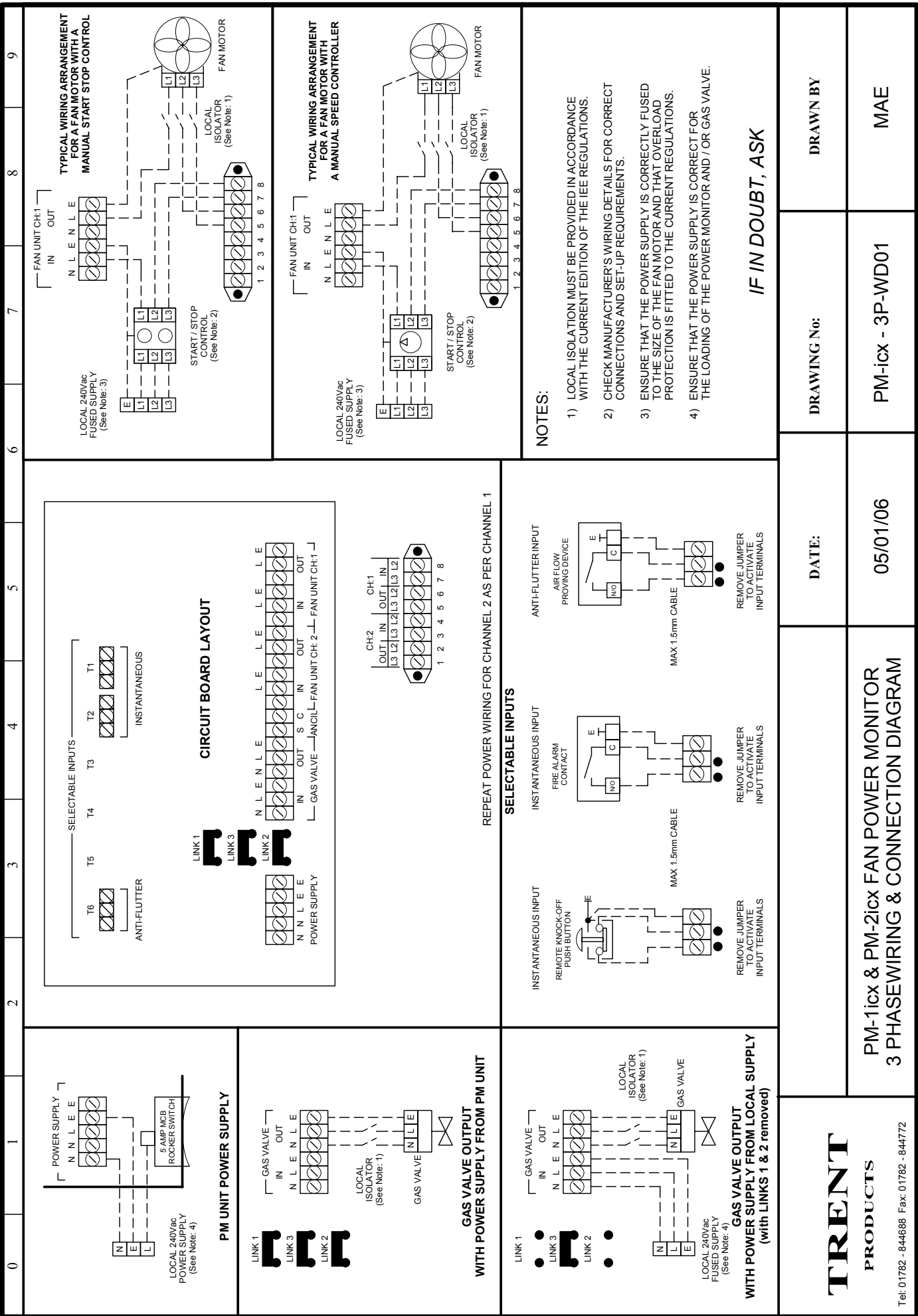

TYPICAL WIRING ARRANGEMENT FOR A FAN MOTOR WITH A MANUAL START STOP CONTROL

TYPICAL WIRING ARRANGEMENT FOR A FAN MOTOR WITH A MANUAL SPEED CONTROLLER

REPEAT POWER WIRING FOR CHANNEL 2 AS PER CHANNEL 1

- NOTES:**
- 1) LOCAL ISOLATION MUST BE PROVIDED IN ACCORDANCE WITH THE CURRENT EDITION OF THE IEE REGULATIONS.
 - 2) CHECK MANUFACTURER'S WIRING DETAILS FOR CORRECT CONNECTIONS AND SET-UP REQUIREMENTS.
 - 3) ENSURE THAT THE POWER SUPPLY IS CORRECTLY FUSED TO THE SIZE OF THE FAN MOTOR AND THAT OVERLOAD PROTECTION IS FITTED TO THE CURRENT REGULATIONS.
 - 4) ENSURE THAT THE POWER SUPPLY IS CORRECT FOR THE LOADING OF THE POWER MONITOR AND / OR GAS VALVE.

IF IN DOUBT, ASK

DRAWING No:

DATE:

DRAWN BY

PM-1icx & PM-2icx FAN POWER MONITOR 3 PHASE WIRING & CONNECTION DIAGRAM

PM-icx - 3P-WD01

MAE

TRENT PRODUCTS

Tel: 01782 - 844688 Fax: 01782 - 844772

PM-2icx Twin Channel PCB

TO CHANGE A TWIN CHANNEL UNIT TO A SINGLE CHANNEL UNIT JUST MOVE BLUE JUMPER FROM J23 AND PLACE ON J10

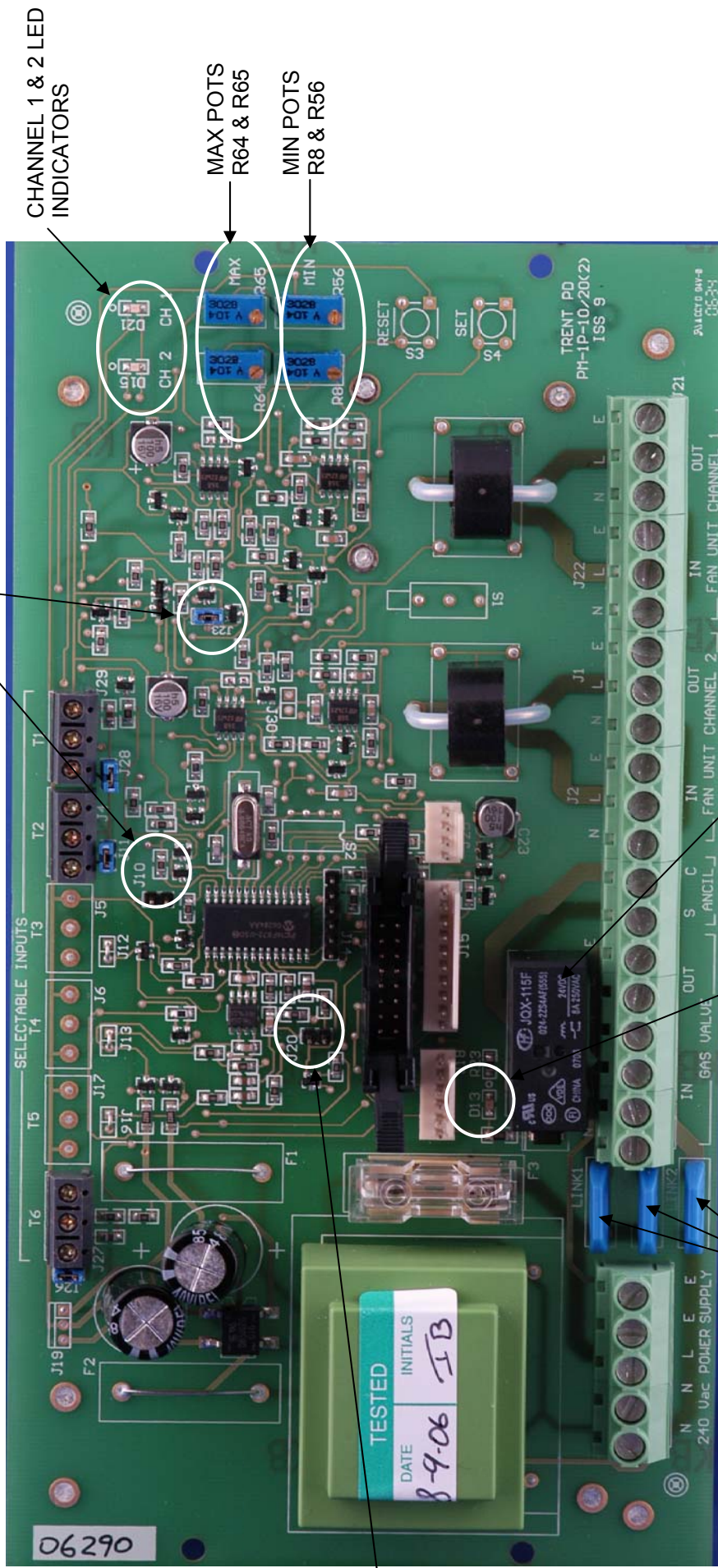

AUTO RESET JUMPER J20

POWER FEED LINKS 1, 2, 3

GAS VALVE RELAY

D13 GAS VALVE OPEN LED

PM-icx the Intelligent answer

FOR FURTHER TECHNICAL ASSISTANCE, PLEASE CONTACT US BY

Phone: 01782 844688

Fax: 01782 844772

E-mail: info@trentproducts.com

Web site: www.trentproducts.com

- Note:
- i) Ensure that the electrical installation has been installed in accordance with the current edition of the IEE regulations.
 - ii) Ensure that the gas installation has been installed in accordance with the current gas regulations and CORGI guide-lines.
 - iii) Ensure that the ventilation and extract system has been set to the correct air flow design levels in accordance with the current regulations.
 - iv) If in doubt, ask! (contact us on or by any of the above).
 - v) Ensure that the client has been shown how to operate the system and that they have been handed the users guide.



This symbol on this product or the package indicates that disposal of this product after its lifecycle could harm the environment. DO NOT dispose of this product (or batteries if used) as unsorted municipal waste. It should be disposed by a specialised company for recycling. This product should be returned to your distributor or to a local recycling service. Respect the local environment rules.

TRENT PRODUCTS
Trent House
Dewsbury Road
Fenton
Stoke-on-Trent
Tel: 01782 844688 Fax: 01782 844772
Web: www.trentproducts.com
e-mail: info@trentcontrols.com