

LS-WSV-xx Water Solenoid Valve

A range of normally-closed water solenoid valves used for water shut-off for safety or control applications.



Model Type	Model	Description
<i>Other sizes available - please contact us</i>	VAL2P - 1/2"	Water solenoid valve (1/2" BSP connection)
	VAL2P - 1"	Water solenoid valve (1" BSP connection)
	VAL2P - 1-1/2"	Water solenoid valve (1-1/2" BSP connection)
	VAL2P - 2"	Water solenoid valve (2" BSP connection)

Technical Data

Power supply	240V (+10% -15%) 50-60 Hz
Power consumption	LS-WSV-1/2" to 1": <12VA LS-GSV- 1-1/2" to 2": <20VA
Response time	16 to 18 millisecond
Maximum Viscosity	12 Centistrokes
Media temperature	-10°C to +90°C
Ambient temperature	-15°C to +40°C
Materials	Brass body with S/S moving parts
Cable entry	PG11 gland
Protection	IP64
Max. pressure	12 bar
Connection	DN (BSP) female threads
Approvals	CE marked



This symbol on this product or the package indicates that disposal of this product after its lifecycle could harm the environment.
DO NOT dispose of this product (or batteries if used) as unsorted municipal waste. It should be disposed by a specialised company for recycling.
This product should be returned to your distributor or to a local recycling service.
Respect the local environment rules.

Dimensions*All dimensions in mm*

Model	H	L	W	Flow L/min
VAL2P - 1/2"	83	64	45	33
VAL2P - 1"	109	100	73	166
VAL2P - 1-1/2"	135	144	102	283
VAL2P - 2"	153	152	119	600

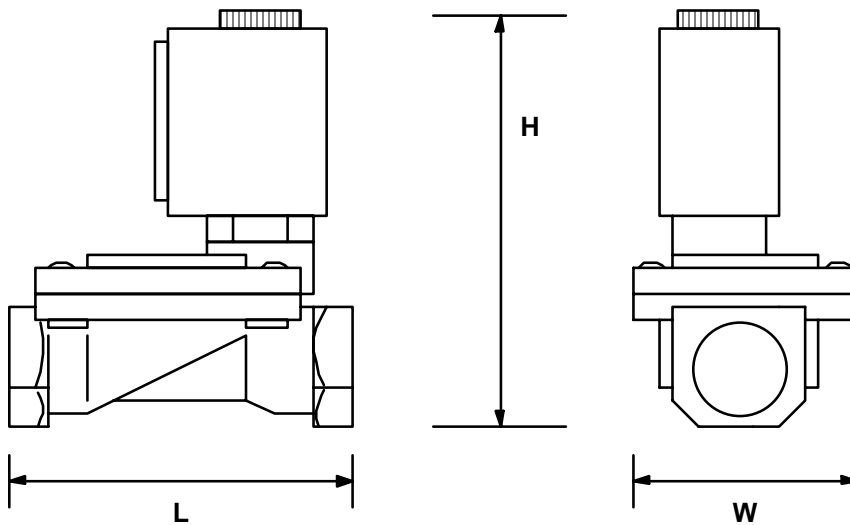

This symbol on this product or the package indicates that disposal of this product after its lifecycle could harm the environment.
 DO NOT dispose of this product (or batteries if used) as unsorted municipal waste. It should be disposed by a specialised company for recycling.
 This product should be returned to your distributor or to a local recycling service.
 Respect the local environment rules.