

GSV-xx Gas Solenoid Valve

A range of normally-closed gas solenoid valves used for gas shut-off for safety or control applications. The range is suitable for various gases, including natural gas, propane, and LPG.



Model Type	Model	Description
<i>Other sizes available - please contact us</i>	GSV-15	Gas solenoid valve (1/2" BSP connection)
	GSV-20	Gas solenoid valve (3/4" BSP connection)
	GSV-25	Gas solenoid valve (1" BSP connection)
	GSV-32	Gas solenoid valve (1 1/4" BSP connection)
	GSV-40	Gas solenoid valve (1 1/2" BSP connection)
	GSV-50	Gas solenoid valve (2" BSP connection)

Technical Data

Power supply	240V (+10% -15%) 50-60 Hz
Power consumption	LS-GSV-15/20/25: 25VA LS-GSV-32/40/50: 50VA
Opening time	< 1 second
Closing time	< 1 second
Max. no. of operations	20 per minute
Ambient temperature	-15°C to 60°C
Coil temperature	approx. 70°C
Cable entry	PG11 gland
Rating	IP54
Max. pressure	200 mbar
Approvals	Class "A" BSEN161:2002 Approved British Gas & European Standards 90/396/EEC - 73/23/EEC - 89/336/EEC Certificate CE EC-87/07/009



This symbol on this product or the package indicates that disposal of this product after its lifecycle could harm the environment.
DO NOT dispose of this product (or batteries if used) as unsorted municipal waste. It should be disposed by a specialised company for recycling.
This product should be returned to your distributor or to a local recycling service.
Respect the local environment rules.

Dimensions*All dimensions in mm*

Model	A	B	C	D
GSV-15	72	112	52	85
GSV-20	86	156	70	96
GSV-25	100	156	75	96
GSV-32	150	214	110	118
GSV-40	150	214	110	118
GSV-50	170	220	135	123

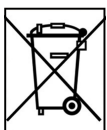
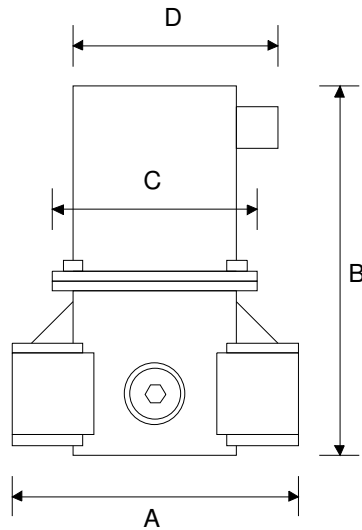

This symbol on this product or the package indicates that disposal of this product after its lifecycle could harm the environment.
 DO NOT dispose of this product (or batteries if used) as unsorted municipal waste. It should be disposed by a specialised company for recycling.
 This product should be returned to your distributor or to a local recycling service.
 Respect the local environment rules.