

## EXAMPLE APPLICATIONS

**CaterSense –03** The example shown combines the units ability to control the starting and stopping of the two fans directly with fan power monitoring and over-current protection of each fan, adjustment of two 0~10v speed controllers at the demand of the cooking level of the catering area along with gas pressure proving of the appliance side of the installation.

System equipment requirements Mode: 03-05

	Qty:	Model No:	Description:
A	1	CaterSense –03	Multi-function controller
B	1	CS-GSV-.....	Gas valve (size: 1/2" to 2" ex-stock)
C	1	CS-GPS-01	Gas pressure sensor
D	1	CS-GVJB-01	Gas valve / pressure sensor junction box
E	1	KO-PB	Remote knock-off button
F	1	CS-SDS-01	Demand sensor
G	2	CS-FSC-.....	Fan speed controller (single phase 6.5A max)

*Option for either indirect power feed upto 10A or 3 phase inverter upto 55kw*

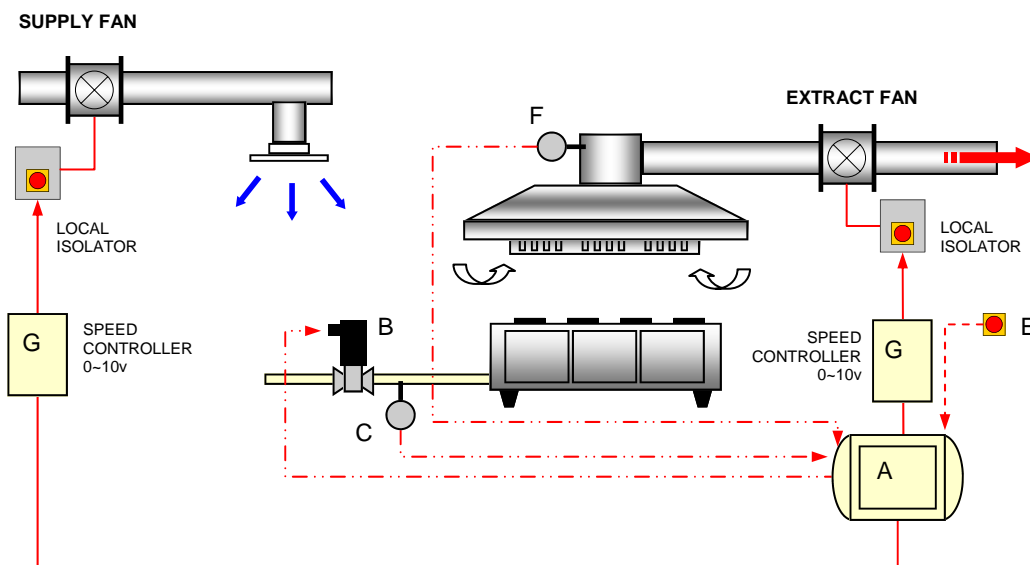

CS-APP-03-05