

3 PHASE INVERTER SPEED CONTROLLERS

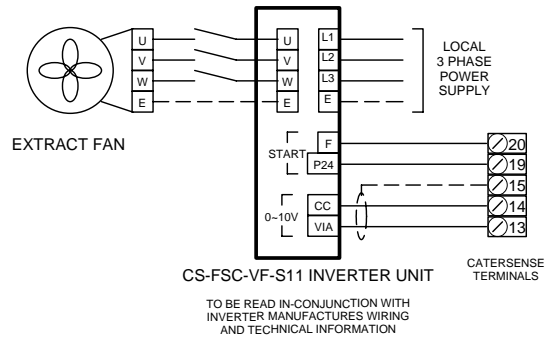

SINGLE PHASE TO 3 PHASE INVERTER SPEED CONTROLLERS

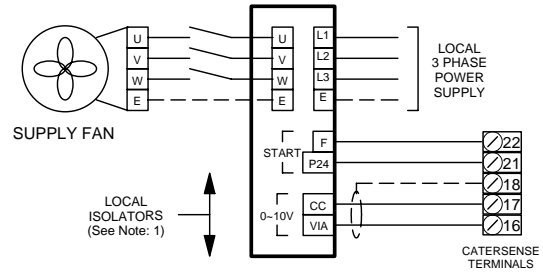
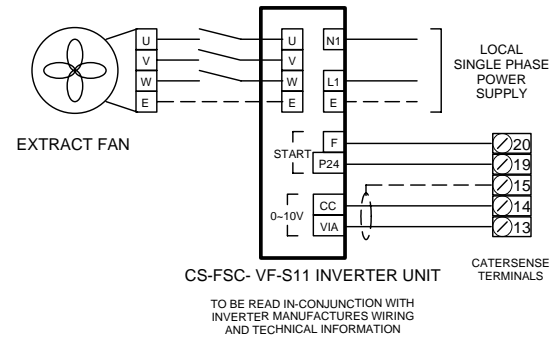
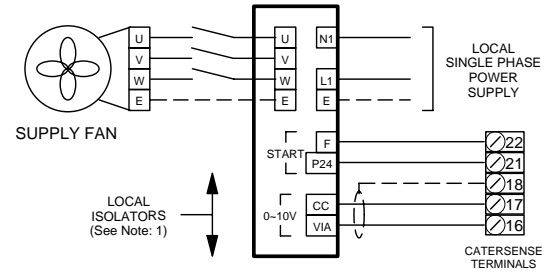

NOTES:

- 1) LOCAL ISOLATION MUST BE PROVIDED IN ACCORDANCE WITH THE CURRENT EDITION OF THE IEE REGULATIONS.
- 2) CHECK MANUFACTURER'S WIRING DETAILS FOR CORRECT CONNECTIONS AND SET-UP REQUIREMENTS.
- 3) ENSURE THAT THE SWITCHED POWER IS CORRECTLY FUSED TO THE LOADING OF THE CATERSENSE AND PLANT ITEMS.

TRENT
PRODUCTS

Tel: 01782 - 844688 Fax: 01782 - 844772

IF IN DOUBT, ASK

**CATERSENSE -3 (FSC) VF-S11 TOSHIBA
WIRING & CONNECTION DIAGRAM**

DATE:

05/01/06

DRAWING No:

**CATERSENSE - 3
WD-03-FSC - VF-S11**

DRAWN BY

MAE