

CaterSense - 04 Controller - Speed Control and Gas Pressure Proving

CaterSense 04 unit is one of our multi-function controllers which can be used in any catering application. It's patented fan power monitor circuit and selectable gas pressure proving enables the unit to start / stop control two fans, speed control them via a range of inbuilt and external speed controllers and even control the supply air temperature via a heater battery to meet BS6173:2009 and DW172.

This product has a number of available inputs which can be used to perform different functions, such as CO2 level monitoring / control with our carbon dioxide sensors.



Model Type	Model	Description
	CaterSense - 04	Controller - GPP + optional single fan

Technical Data		
Power supply	240Vac	50Hz (L,N,& E)
Number of sensor channels	Two	
Current rating of monitor	1 to 8Amp	(inbuilt) 1 to 100Amp external
Voltage range of fans	Single phase	(240Vac) or three phase 415Vac
Gas valve output	240Vac	(L,N & E)
Fire alarm input	Volt-free	to open on alarm
Remote knock-off	Volt-free	to open on activation

Typical Application - Extract Fan Canopy

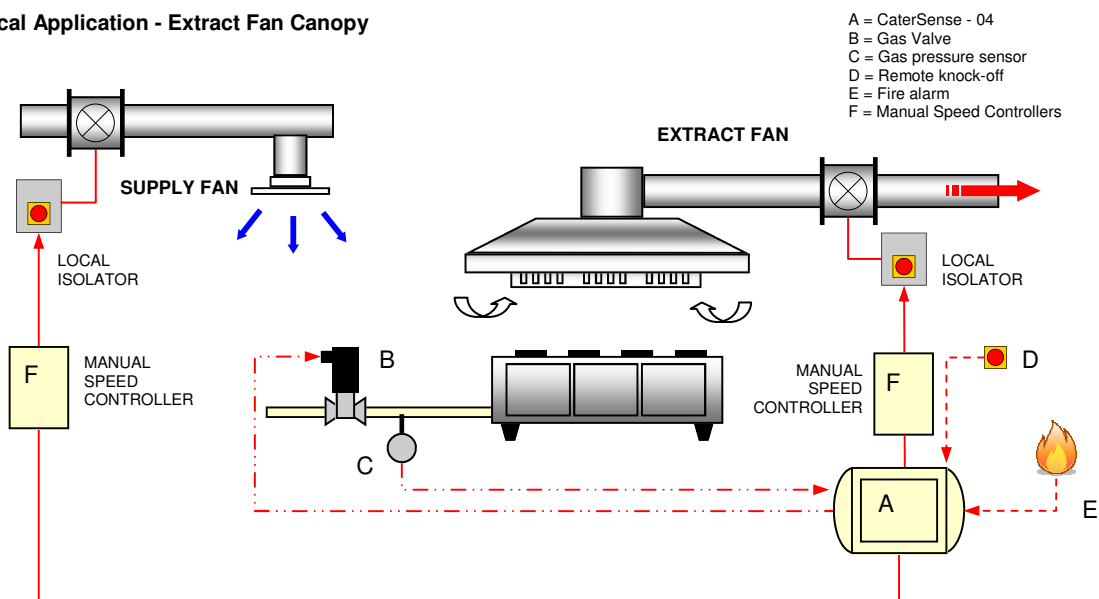

Wiring Diagram

The CaterSense system has two sets of terminals all mounted along the top edge of the main PCB circuit board.

Terminals 1 to 22 are the smaller terminals (1.5 mm² cable) and are used for the sensors, inter-locking devices, remote speed and on/off control.

Terminals 23 to 34 are the larger terminals (4 mm² cable) and are for the power connections for the fans, gas valve and power supply to the unit.

The terminals are of the rising clamp type protection.

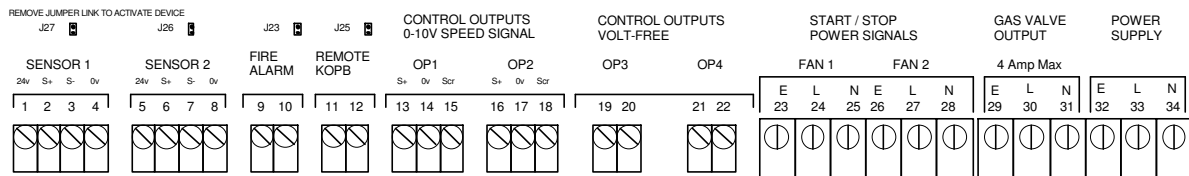

Fitting Instructions

The **CaterSense - 04** unit has six (6) mounting holes which can be used (as shown)

Note: Ensure that the enclosure is mounted on a clean and level surface away from the direct cooking area or surfaces.

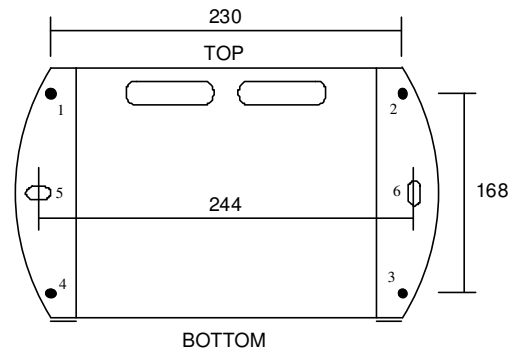

Ancillary Products

Remote Knock-off Buttons



- RKPB-01 Knock-off
- RKPB-02 Key
- RKPB-03 Key + Shroud

Remote Sensors



- CS-GPS-01
Gas Pressure Sensor



- CS-RCT-01
- CS-RCT-02
Remote Current Sensors

Gas Valves



- GV Valves
1/2" to 2-1/2" BSP



- CS-CO2-01
Carbon Dioxide Sensor

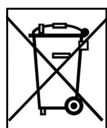

This symbol on this product or the package indicates that disposal of this product after its lifecycle could harm the environment. DO NOT dispose of this product (or batteries if used) as unsorted municipal waste. It should be disposed by a specialised company for recycling. This product should be returned to your distributor or to a local recycling service. Respect the local environment rules.