

## VAL3P-xx 3 Port LPHW Control Valve

A range of pressure balanced control valves for domestic hot water, fan coil units and small heater / cooler batteries; hot water or cold water (max: 50% glycol), water quality VD12035.

Used with a fully modulating actuator controlled via our range of controllers. CaterSense, VeroVent and ClassVent.



Model Type	Model	Description
<i>Other sizes available - please contact us</i>	<b>VAL3P-15E 1.0</b>	3 Port control valve (15mm connection)
	<b>VAL3P-15E 1.6</b>	3 Port control valve (15mm connection)
	<b>VAL3P-20E 2.5</b>	3 Port control valve (20mm connection)
	<b>VAL3P-20E 4.0</b>	3 Port control valve (20mm connection)
	<b>VAL3P-25E 6.3</b>	3 Port control valve (25mm connection)
	<b>VAL3P-25E 10.0</b>	3 Port control valve (25mm connection)
	<b>VAL3P-32E 16</b>	3 Port control valve (32mm connection)
	<b>VAL3P-40E 25</b>	3 Port control valve (40mm connection)

### Technical Data

<b>Actuator</b>	<b>Power supply</b>	24V (+10% -15%) 50-60 Hz
	<b>Control Signal</b>	0~10V fully modulating
<b>Valve body</b>	<b>Valve type</b>	3-way mixing
	<b>Materials</b>	Body red brass, stem S/S, plug brass
	<b>Action</b>	Stem retraction opens A - AB
	<b>Stroke</b>	6.5mm
	<b>Media temperature</b>	2~120°C (upto 20mm) 2~130°C (25 to 40mm)
	<b>Static pressure</b>	PN16
	<b>Port connection type</b>	Flat sealing
	<b>Flow characteristic</b>	Linear



This symbol on this product or the package indicates that disposal of this product after its lifecycle could harm the environment. DO NOT dispose of this product (or batteries if used) as unsorted municipal waste. It should be disposed by a specialised company for recycling. This product should be returned to your distributor or to a local recycling service. Respect the local environment rules.

**M7410E VALVE ACTUATOR  
WIRING AND SPINDLE SETTINGS**

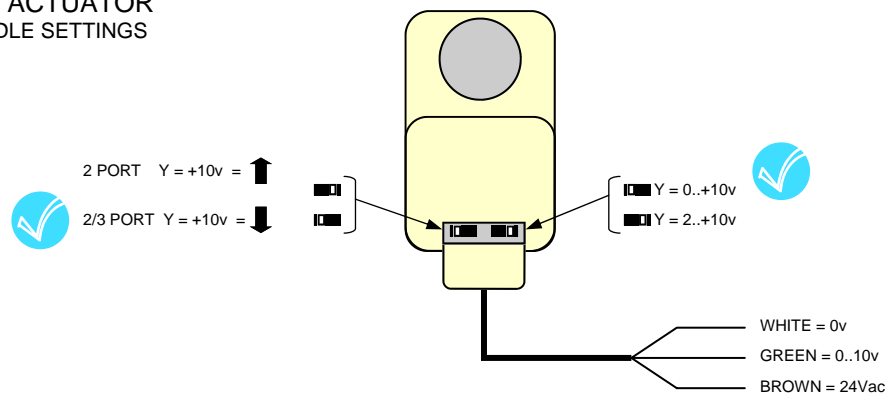

**TYPICAL FROST COIL HEATER BATTERY  
ARRANGEMENT WITH FREEZE  
PROTECTION THERMOSTAT**

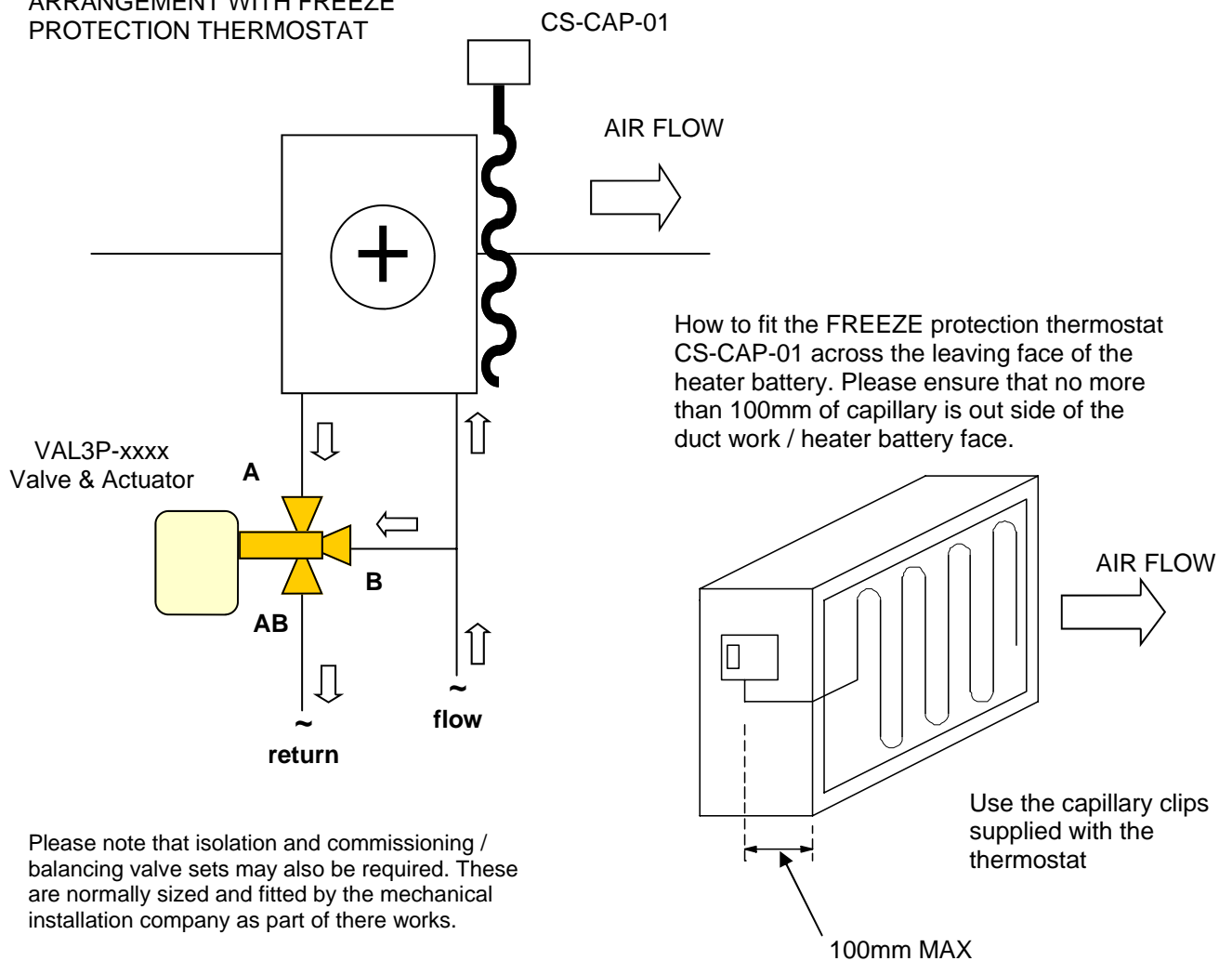

Please note that isolation and commissioning / balancing valve sets may also be required. These are normally sized and fitted by the mechanical installation company as part of there works.



This symbol on this product or the package indicates that disposal of this product after its lifecycle could harm the environment. DO NOT dispose of this product (or batteries if used) as unsorted municipal waste. It should be disposed by a specialised company for recycling. This product should be returned to your distributor or to a local recycling service. Respect the local environment rules.